

CANDIDATE
NAME

CENTRE
NUMBER

--	--	--	--	--

CANDIDATE
NUMBER

--	--	--	--

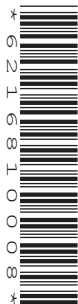

COMBINED SCIENCE

0653/33

Paper 3 (Core)

May/June 2017

1 hour 15 minutes

Candidates answer on the Question Paper.

No Additional Materials are required.

READ THESE INSTRUCTIONS FIRST

Write your Centre number, candidate number and name on all the work you hand in.

Write in dark blue or black pen.

You may use an HB pencil for any diagrams or graphs.

Do not use staples, paper clips, glue or correction fluid.

DO NOT WRITE IN ANY BARCODES.

Answer **all** questions.

Electronic calculators may be used.

You may lose marks if you do not show your working or if you do not use appropriate units.

A copy of the Periodic Table is printed on page 24.

At the end of the examination, fasten all your work securely together.

The number of marks is given in brackets [] at the end of each question or part question.

This document consists of **22** printed pages and **2** blank pages.

- 1 (a) Use lines to connect the box on the left to different boxes on the right to make correct sentences.

One is done for you. The sentence reads 'Enzymes work best in a narrow pH range'.

Draw **three** more lines to make three more correct sentences.

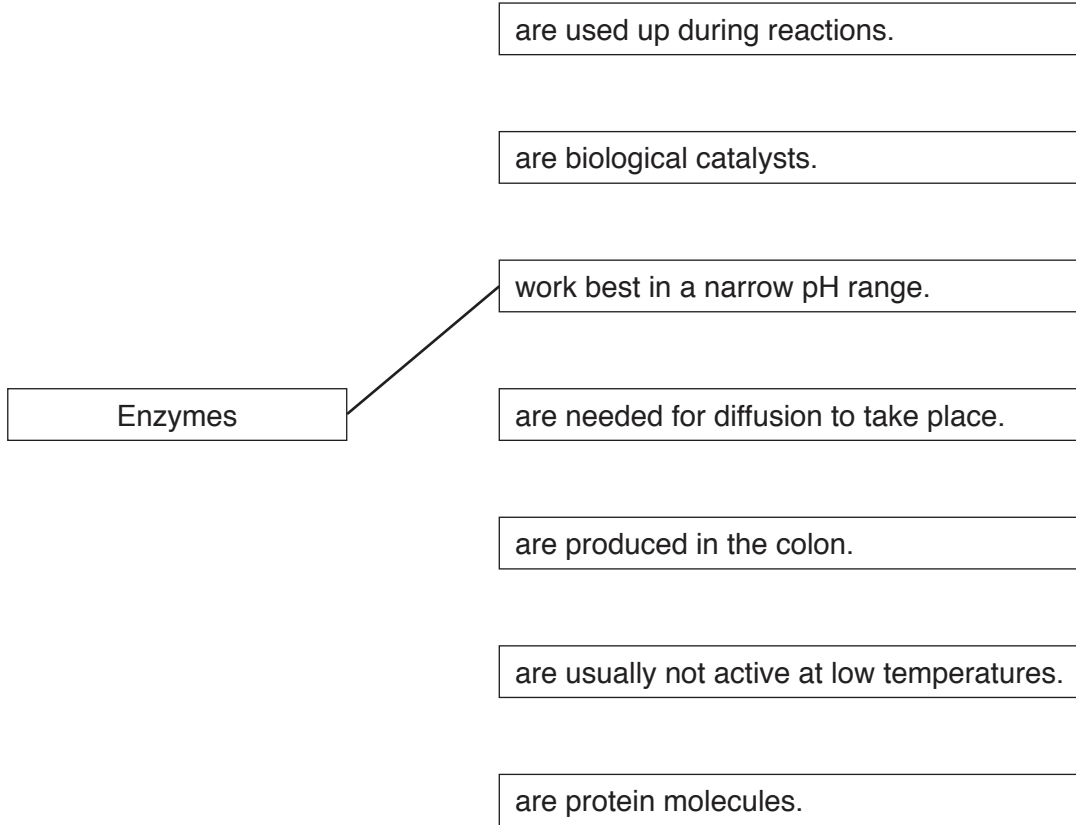

[3]

- (b) Digestive enzymes are added to food in the alimentary canal. They speed up the chemical digestion of food molecules.

Explain why chemical digestion of food molecules is necessary.

.....

.....

..... [2]

(c) When many glucose molecules join together, larger molecules are formed.

Fig. 1.1 shows a glucose molecule and part of a larger molecule.

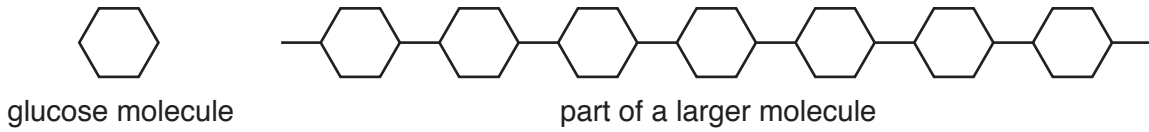

Fig. 1.1

Draw a circle around **two** examples of the larger molecules formed when glucose molecules join together.

- | | | | |
|-------------------|-----------------|-------------------|-----------------|
| amino acid | fat | fatty acid | glycerol |
| | glycogen | protein | starch |

[2]

(d) A student adds an enzyme to a solution and incubates it at 37 °C for 10 minutes. He wants to find out if the enzyme causes reducing sugar to be produced.

(i) Give the name of the test he can do to find out if reducing sugar is produced. State the positive result of this test.

test

positive result

[2]

(ii) The student knows that reaction rates often increase at higher temperatures. He repeats the experiment at 80 °C.

Predict what happens and explain your answer.

prediction

explanation

[2]

(e) Sugar is produced by photosynthesis in plants. Carbon dioxide and water are the raw materials needed.

State **two** conditions that must be present during photosynthesis for the raw materials to react together.

1.
2.

[2]

- 2 (a) A teacher places the first three metals of Group I in the Periodic Table into separate beakers of water. This is shown in Fig. 2.1.

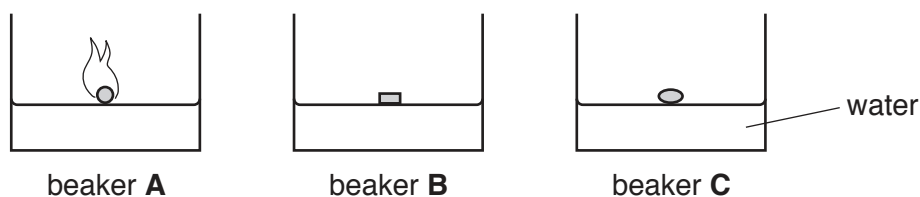

Fig. 2.1

The three pieces of metal are the same size.

A student records her observations in Table 2.1.

Table 2.1

beaker	the metal floats	the metal melts	time for metal to fully react in seconds	flames are seen
A	yes	yes	15	yes
B	yes	no	60	no
C	yes	yes	40	no

- (i) Use the information in Table 2.1 to identify the three metals in beakers **A**, **B** and **C**.

beaker **A**

beaker **B**

beaker **C**

[2]

- (ii) Name the gas produced when Group I metals react with water.

..... [1]

- (iii) When the metals have completely reacted, the teacher places pieces of red litmus paper and blue litmus paper into each beaker.

Describe the changes, if any, that are seen.

red litmus paper

blue litmus paper

[1]

(b) The student places pieces of copper, iron, magnesium and zinc into dilute hydrochloric acid.

(i) State which of the four metals react fastest.

..... [1]

(ii) State which of the four metals does not react at all.

..... [1]

(iii) Suggest why Group I metals **must not** be added to dilute hydrochloric acid.

.....
..... [1]

(c) Saucepans are usually made from an iron alloy rather than from pure iron.

Some coins are made from a copper alloy rather than from pure copper.

Explain why these alloys are used instead of the pure metals.

(i) iron alloy for saucepans

.....
..... [1]

(ii) copper alloy for coins

.....
..... [1]

- 3 Fig. 3.1 shows an aircraft flying at a constant height and constant speed above the Earth's surface. The arrows labelled **A**, **B**, **C** and **D** show the forces acting on the aircraft.

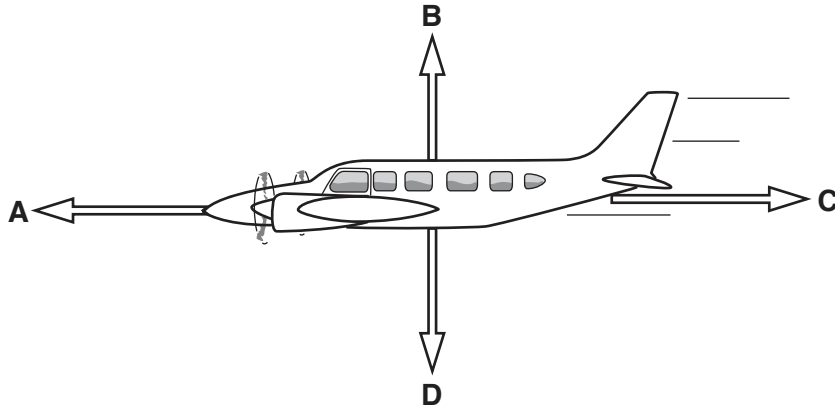

Fig. 3.1

- (a) (i) Complete Table 3.1 using the letters **A**, **B**, **C** and **D**.

Table 3.1

name of force	letter on Fig. 3.1
driving force	
frictional force	
lifting force	
weight	

[2]

- (ii) Force **D** is measured and found to be 500 000 N.

State whether force **B** is 500 000 N or has a different value.

Give a reason for your answer.

.....

 [1]

- (iii) State which force should be increased by the pilot

1. to make the aircraft fly at a faster speed,
2. to make the aircraft go up to a higher height.

[2]

(b) The speed of the aircraft is 600 km/h.

(i) Calculate the speed of the aircraft in m/s.

Show your working.

speed = m/s [1]

(ii) The aircraft travels at this speed for a distance of 2700 km.

The pilot tells his passengers that the flight time will be 4 hours 30 minutes.

Show by calculation that the pilot is correct.

[1]

(c) The aircraft slows down and descends to a lower height.

Describe the energy changes that have taken place for the aircraft.

.....
.....
..... [2]

- (d) Another aircraft takes off and climbs to cruising height. It then travels at a constant speed until it descends and lands.

On Fig. 3.2 sketch the shape of the speed-time graph for the whole journey of this aircraft from take-off to landing.

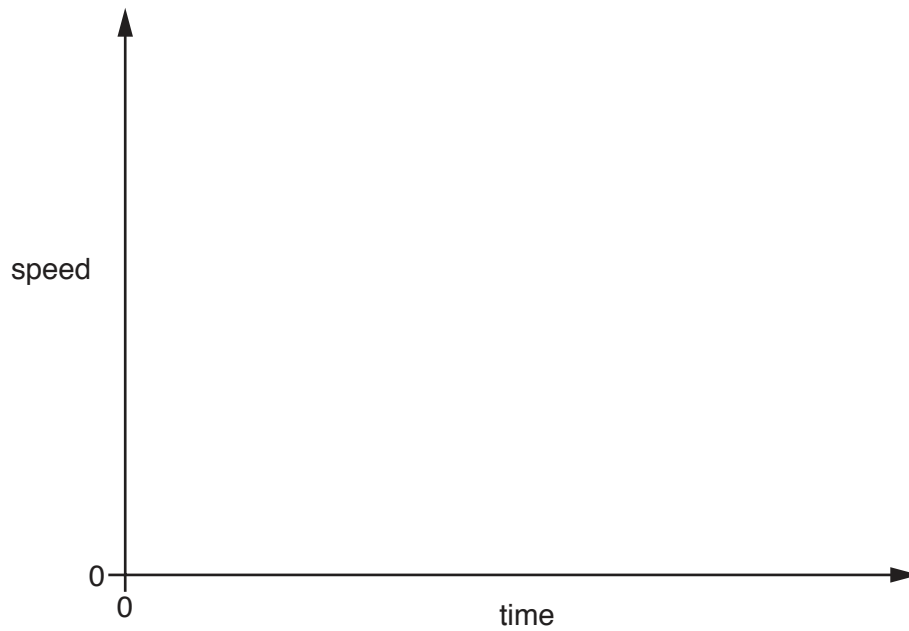

Fig. 3.2

[2]

Please turn over for Question 4

4 (a) Fig. 4.1 shows a diagram of the internal structure of the heart.

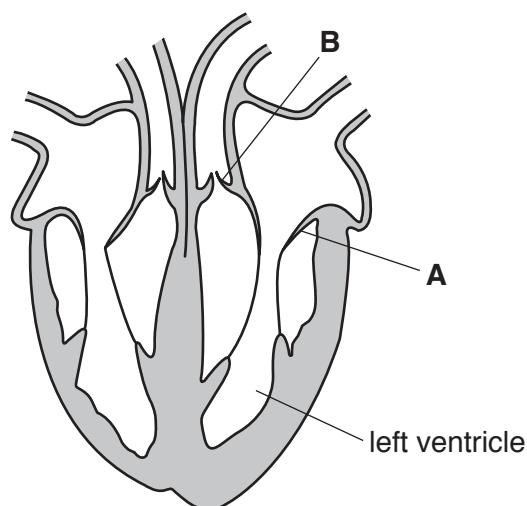

Fig. 4.1

(i) The ventricles contract to send blood out of the heart.

State what happens to the valves at **A** and **B** when the ventricles contract.

A

B

[1]

(ii) Explain why it is essential to have valves **A** and **B** in the heart.

.....

..... [1]

(b) The hormone adrenaline is secreted into the blood by the adrenal glands which are above the kidneys. One of the effects of adrenaline is to increase the heart rate.

(i) Describe **one** situation when the rate of adrenaline secretion increases rapidly.

.....

..... [1]

(ii) State how the hormone adrenaline is removed from the blood.

..... [1]

(c) Describe the functions of the following parts of the blood.

red blood cells

.....
.....
.....

plasma

.....
.....
.....

[2]

- 5 (a) Petroleum is a mixture of hydrocarbons.

It is separated into more useful parts using the industrial apparatus shown in Fig. 5.1.

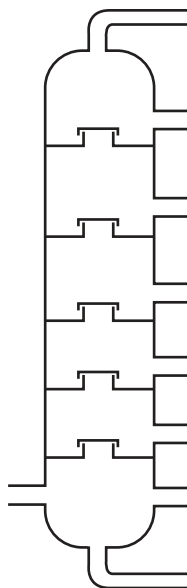

Fig. 5.1

- (i) Name the process that occurs in this industrial apparatus.

..... [1]

- (ii) Suggest why this process involves a physical change and not a chemical change.

.....

 [1]

- (iii) Refinery gas is obtained from petroleum.

State **one** use for refinery gas.

..... [1]

- (b) The main compound in natural gas has the formula CH_4 .

- (i) Name this compound.

..... [1]

- (ii) State the total number of atoms and the number of different elements shown in the formula CH_4 .

number of atoms

number of elements

[1]

- (iii) Complete the diagram to show the structure of one molecule of CH_4 .

C—

[1]

- (c) Petroleum and natural gas are fossil fuels.

Name **one** other fossil fuel.

..... [1]

6 An aircraft is flying at a height of 10 000 m. Outside the aircraft the temperature is -55°C , but inside the aircraft the temperature is kept at 21°C .

(a) (i) State the main method of thermal energy transfer from air inside the aircraft to the outside.

..... [1]

(ii) Suggest how the construction of the aircraft should be designed to reduce this loss of thermal energy.

.....

..... [1]

(b) Inside the aircraft's jet engines, the temperature reaches 1700°C as the jet fuel burns. The combustion of the fuel forms exhaust gases containing carbon dioxide and water molecules.

(i) State which of the diagrams in Fig. 6.1, X, Y or Z, shows the arrangement of these molecules as they are formed in the engine.

Give a reason for your answer.

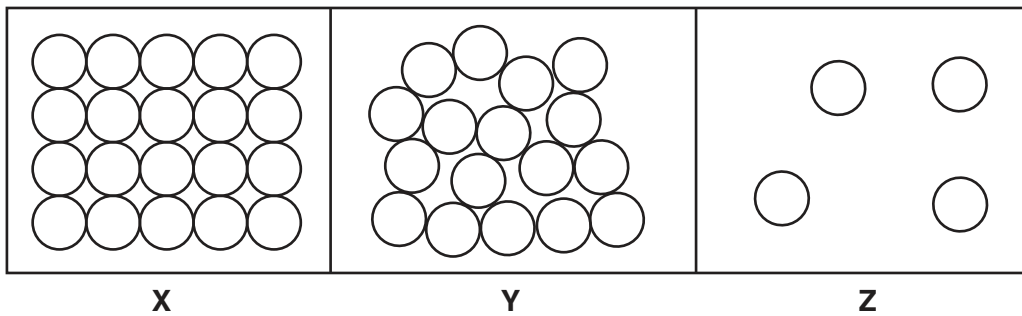

Fig. 6.1

diagram

reason

.....

[1]

(ii) Fig. 6.2 shows the white trails across the sky left by the jet engines of an aircraft.



Fig. 6.2

Suggest what these white trails are made of. Give a reason for your answer.

The white trails are made of

reason

.....

[2]

(c) Radar is a method of tracking aircraft from the ground using microwaves. Air traffic control can also use radio waves to talk to the pilot.

On Fig. 6.3, put microwaves and radio waves in their correct places in the incomplete electromagnetic spectrum.

gamma radiation			visible light			
-----------------	--	--	---------------	--	--	--

Fig. 6.3

[2]

(d) The jet engines of the aircraft in Fig. 6.2 emit a very loud noise. Most of this noise occurs at low frequencies around 100 Hz.

Describe the pitch and amplitude of the sound produced.

pitch

amplitude

[2]

- 7 Fig. 7.1 shows some of the organisms in a lake. Algae are tiny water plants that float on the surface of the lake.

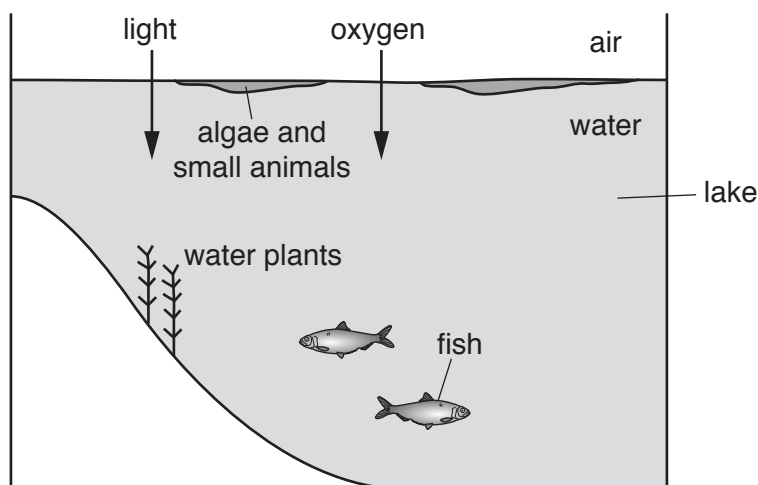

Fig. 7.1

- (a) (i) Explain why the fish in the water need oxygen.

.....
 [1]

- (ii) The concentration of oxygen is higher in the air than in the water.

Name the process which causes oxygen molecules to go from the air into the water.

..... [1]

- (iii) Describe another source of oxygen for the fish in the water.

.....
 [1]

(b) The feeding relationships of the organisms in Fig. 7.1 are as follows.

- the small animals feed on algae
- the fish feed on the algae, water plants and small animals.

(i) Use the information provided to complete the food web which has been started below.

small animals

fish

algae

water plants

[2]

(ii) From the organisms in Fig. 7.1 name

a herbivore,

a producer.

[2]

8 (a) Water is extracted from a river and then treated to make it suitable for people to use.

Two processes, **J** and chlorination, are used in the purification of the water supply, as shown in Fig. 8.1.

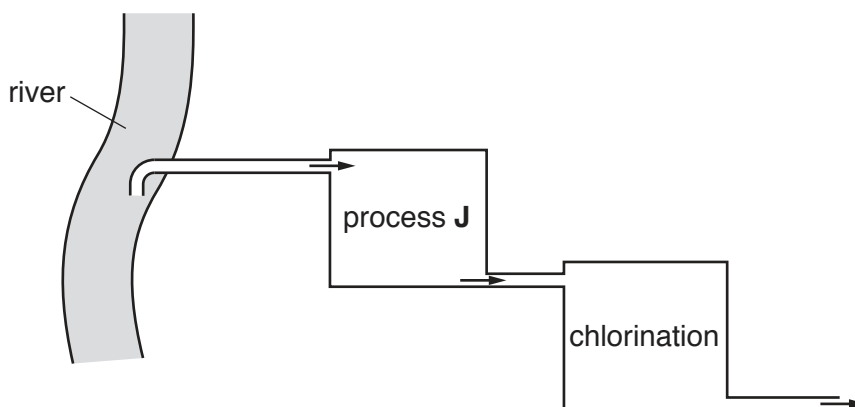

Fig. 8.1

(i) Process **J** removes insoluble solids from the water.

Name process **J**.

..... [1]

(ii) Explain why chlorine is added to the water supply.

.....
 [1]

(iii) Describe a chemical test for chlorine gas.

State the positive result of this test.

test

result

..... [2]

(b) Hydrogen chloride is formed when chlorine reacts with hydrogen.

(i) Construct the word equation for this reaction.



[1]

- (ii) State the type of chemical bond that forms between non-metallic elements such as chlorine and hydrogen.

Describe how electrons are involved in this bond.

bonding type

explanation

..... [2]

- (iii) In a molecule of hydrogen chloride, an atom of hydrogen is bonded to an atom of chlorine.

State the formula of hydrogen chloride.

..... [1]

- (c) Chlorine is made during the electrolysis of aqueous copper chloride using inert electrodes.

- (i) Name the electrode at which chlorine forms during this process.

..... [1]

- (ii) State the product that forms at the **other** electrode.

..... [1]

- (iii) Identify the electrolyte used in this process.

..... [1]

- 9 Fig. 9.1 shows a simple circuit set up to investigate the electrical properties of a lamp.

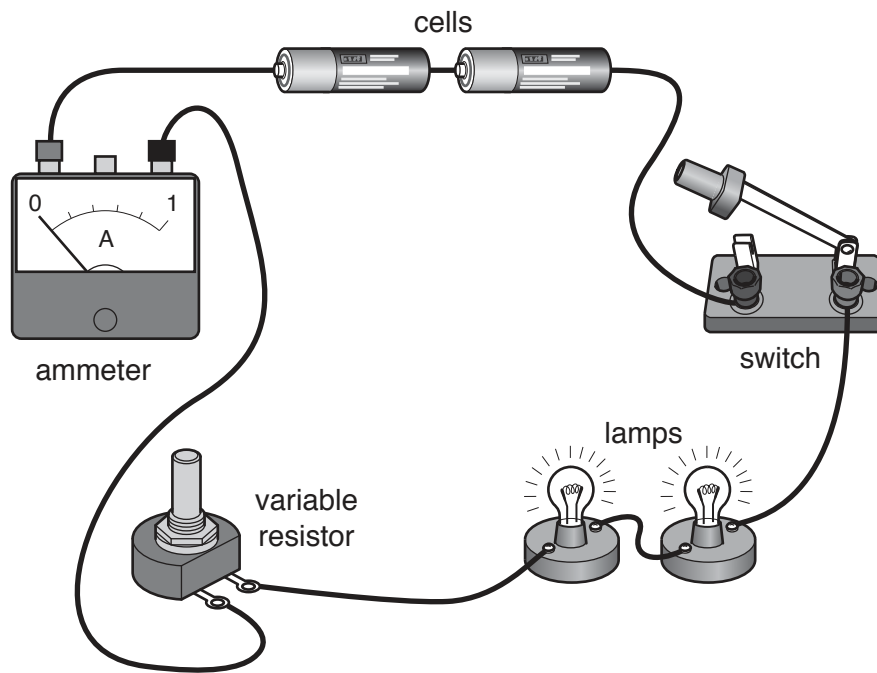

Fig. 9.1

- (a) On Fig. 9.2 use the correct circuit symbols to complete the circuit diagram for the circuit shown in Fig. 9.1.

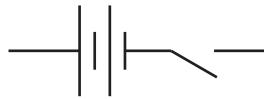

Fig. 9.2

[3]

(b) The two lamps in the circuit are identical.

A voltmeter connected across the two lamps reads 2.4 V.

The ammeter reads 0.6 A.

Calculate the resistance of one lamp.

State the formula used and show your working.

formula

working

resistance = Ω [3]

(c) The resistance of the variable resistor is reduced.

State the effect this will have on the brightness of the two lamps.

Give a reason for your answer.

.....
.....
..... [1]

